



INSTALLATION AND MAINTENANCE GUIDE FOR STANDARD AND ATEX VERSION

**DEDICATED FOR TOXIC AND CORROSIVE
ENVIRONNEMENTS!**

WARNING:
*Please read this manual before installation
and follow the procedures extremely
carefully!*

SEAT Ventilation SAS
Parc Technologique Delta Sud 09340 Verniolle- FRANCE
Tel. (33) 5 61 69 84 43 Fax. (33) 5 61 67 86 03
www.seat-ventilation.com E-mail: info@seat-ventilation.com

SERIE SEAT
STANDARD ET ATEX VERSION



SERIE STORM
STANDARD ET ATEX VERSION

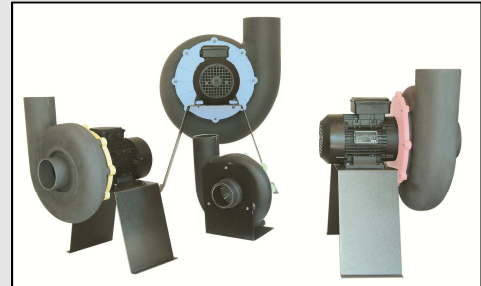

SERIE JET
STANDARD ET ATEX VERSION



The attached installation instructions are issued for guidance only. The installer assumes ultimate responsibility for ensuring that current installation regulations are fully observed and that the exhaust fan receives adequate protection from adverse electrical, mechanical, thermal or environmental conditions.

LIABILITY & WARRANTY:

SEAT VENTILATION warrants its equipment, products and parts, to be free from defects in workmanship and material under normal use and service for two years after delivery to the first user. Products must be stored in a clean dry place protected from temperature fluctuations. Products must be returned to the point of purchase, with bill of sale, within two years of purchase. If factory return is required, as determined by the distributor.

1. INSTALLATION

Before installation, this manual must be readed carefully.

- ⇒ Before installation check that they are no foreign bodies in the coil or in the intake and pressure connections
- ⇒ Before installation check whether all the locking screws (including the motor screws) are tightened properly
- ⇒ Check the electrical connections and wiring (see page 9)
- ⇒ Fan should be connected to ductwork with PVC sleeves to reduce vibrations and noise
- ⇒ If exhaust stacks are mounted on SEAT or STORM Series fan outlet (ubplast discharge), the weight of the stack must not be supported by fan housing.
- ⇒ Avoid continous temperature use higher than 70°C
- ⇒ Please do the enclosed pedestal or kit roof installation as indicated on pages 4 to 6
- ⇒ If rain water can enter the fan housing then a drain plug with hose connector should be fitted at the lowest point of the housing
- ⇒ **Use ATEX version for the explosive atmospheres**

!!WARNING:

For the SEAT Series, for each model, the impeller turn in a one direction, LG or RD. Housing montage was planed in function of this direction of rotation: in case of housing inversion, the fan will not deliver anymore the real performances.

IMPELLER DIRECTION OF ROTATION

(viewed from inlet side)

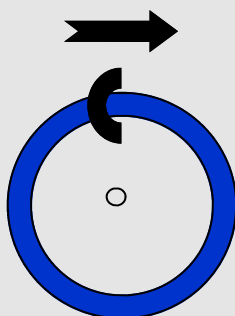

LG

RD

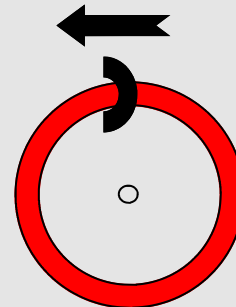

SEAT SERIES

ROOF UNIT KIT MOUNT



1



2



3



4



5



6



7



8



9



10



11



12



13



14

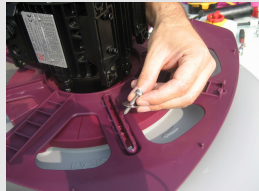

15



16

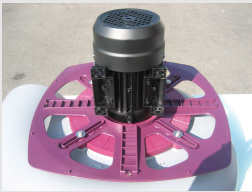

17



18

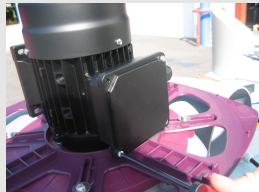

19



20

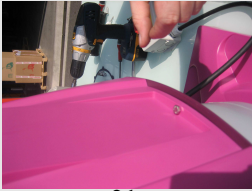

21



22



23



24



25



26

- 1) Components of Kit Roof: roof curb bare, motor cap, cap bracket, exhaust cap
- 2) Place the cap bracket on the motor with the screwing inserts upwards
- 3) Fix the motor flange
- 4) Place the O-seal ring
- 5) Place the impeller
- 6) Push in the impeller
- 7) Screw the hub cap on the motor shaft
- 8) Get in the hub cap
- 9) Place the roof curb bare O-seal-ring
- 10) Place the roof curb bare on the housing
- 11) Screw the roof curbe bare
- 12) Turn over the housing
- 13) Place the motor/impeller part

Reinforce the base before placing the roof curb bare for a motor weight more than 20kgs

- 14, 15, 16, 17) Screw the motor flange and the cap bracket on the housing as indicated in the pictures
- 18) Do the correct wiring between the switch and the motor, respecting the tension
- 19) Screw back on the terminal box hood
- 20, 21) Place the motor cap and screw it
- 22, 23, 24) Screw the switch on the flat side of the motor cap
- 25) Place the exhaust cap at the outlet
- 26) Assembling finished.

SEAT SERIES

ATTACHEMENT OF SEAT FAN TO PEDESTAL



1/

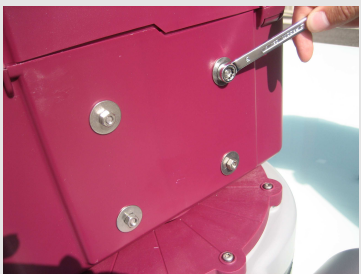

1/Installation composed by: one fan with wired motor, one disconnect switch (optionnal), one enclosed pedestal.

2, 3/ Insert the four bolts into the holes in the motor feet.

4/ Place the **wired** motor inside the pedestal; do not forget to lock the washers.

5, 6/ Fix the switch (optionnal)

JET SERIES

JET 20 (YELLOW), JET 25 (RED), JET 30 (BLUE)



- ⇒ **Check wheel rotation prior to securing JET fan in position.**
- ⇒ Secure fan in place by means of screws drilled through square base (round for JET 30).
- ⇒ Attach fan inlet to ductwork with flexible connections.

STORM SERIES

STORM 10, STORM 12, STORM 14, STORM 16

All STORM models are available only in LG direction. The fan will only function properly if the wheel is rotating in the 8 of standard discharge LG positions by 45° increments.

Assembly drawing for Storm 12, Storm 14 and Storm 16

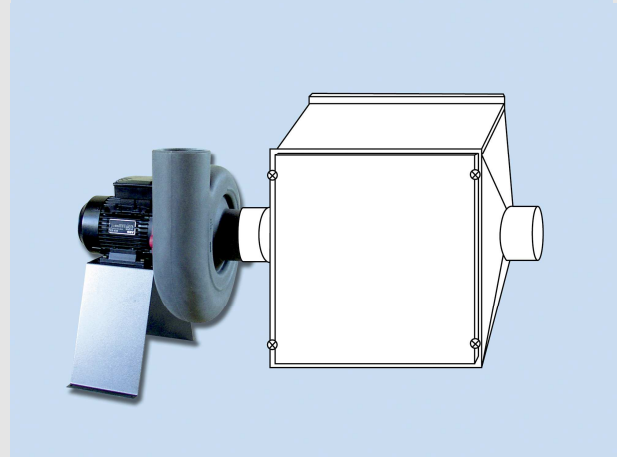
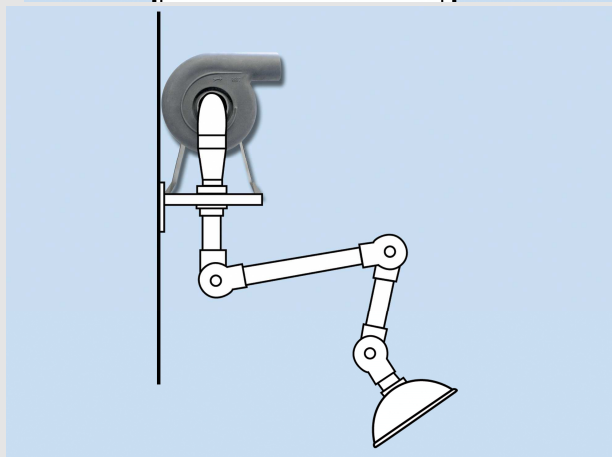
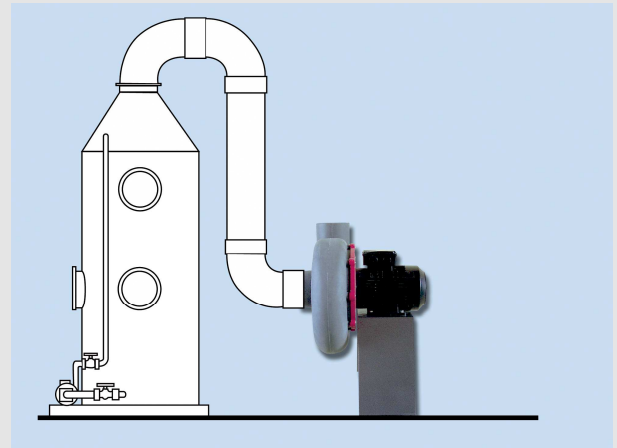
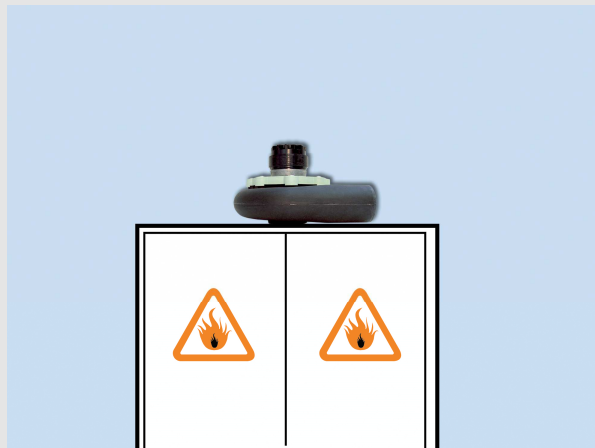
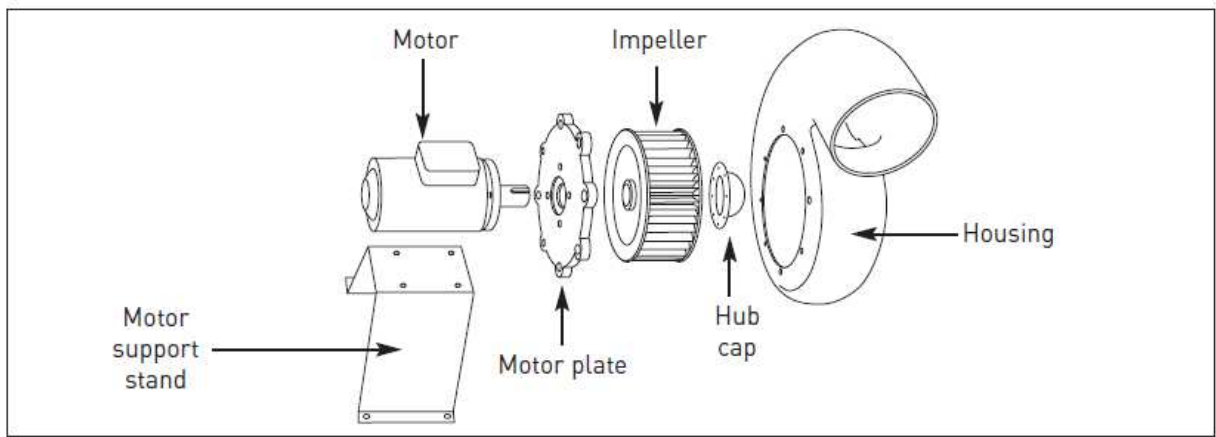

FINDING BREAKAGES

Problem found	Cause	Solution
Lack of capacity	Impeller obstructed	Clean the impeller
	Direction of rotation inverted	Check connection of winding on motor terminal box
	Insufficient speed of rotation	Check transmission, check that the belts do not slide
Excessive air capacity	Speed of rotation	Check direction of rotation; check speed of motor rotation, voltage, defects in winding
Insufficient pressure	Speed of rotation too low	Clean tubes and hood, check position of the shutters
Start up difficult	Excessive power absorption	Check direction of rotation; check the conditions of turbulence at aspiration; check rotation speed of the motor
Excessive noise	Elevated number of rotations to obtain the required performance	Choose an appliance with a bigger size equal to the performance
	Break down of the bearings	Check bearing wear
Vibrations	Support structure not suitable	Add weights to the structure to make it more stable

3. START UP

Prior to commissioning and initial start up, please compare the motor power with the system tension and frequency and check the electrical connections if wired at the factory. The motor must be equipped with a ON/OFF switch according to EEC Machinery Directive of 14th June 1989 (89/392 EEC). The electric cable must be protected against spoiling and conceived in accordance with the observed power.

4. FONCTIONING

- ⇒ The fan must be protected against surging
- ⇒ The deposits on the impeller could cause impeller break; ensure their clearance;
- ⇒ Even in case of default of power supply, the functioning maxim temperature should not be exceeded
- ⇒ The plastic fans are not adapted for the solid particles exhaust
- ⇒ Please use ATEX version for potentially explosive atmospheres

5. MAINTENANCE

After first month functioning, the fan must be maintained as follows:

- ⇒ Check the smooth running of the fan
- ⇒ Check the motor temperature
- ⇒ Remove any dusts deposits on the impeller and the motor

The fan may only be maintained by trained personnel who are authorised to carry out such work.

ATEX VERSION SPECIFICATIONS



Our fans are also available in ATEX version, known outside Europe as explosionproof, with zone 2, EEx-d, category 3G, explosion group IIB & IIA, T4 execution in accordance with ATEX directive 94/9/CE and EN1127-1, EN 13463-1 standards.

In consequence of these technical and legislative provisions it's necessary to take the following information into consideration when you install our ATEX fans:

Zone classification 2: is an area in which explosive atmospheres as a result of a mixture of air and flammable gases , vapours or mist do not normally occur or occur for a short time only during normal operating conditions. Experts generally agree that the term « short time » corresponds to a period of approx. 30 minutes per year.

Temperature class T4: is the enclosure class temperature with 135°C maximum surface temperature of motor including 40°C ambient temperature.

Category 3G: suitable for installation in surface plants for GAS category for a normal protection level guaranteed by the equipment.

Explosion group IIB & IIA : combustible gases and vapours are divided into groups according to their explosive capacity.

All ATEX motors used with an inverter must be equipped with thermistors PTC/PTO to control the temperature.

The installation and repairs have to be carried out only by the authorized workshops.

ATEX declaration of conformity available on our web site.

PARC TECHNOLOGIQUE DELTA SUD

09340 VERNIOLLE FRANCE

TEL: 33 (0)5 61 69 84 43

FAX: 33 (0)5 61 67 86 03

E-mail: info@set-ventilation.com

www.seat-ventilation.com

