



***Venture***  
***Industries***  
***Sp. z o.o.***

Configuration of basic parameters of inverters LG iG5A on fan  
example KEF/4-225/104-110T IE3



Inverter is used to regulate the motors. In order to control the fan operation, the motor data must be entered in the inverter and set the speed setting method and start/stop method. In this manual you will see an example for set speed setting method and start, stop method from inverter panel.



[Rys. 1] Inverter Panel



**ATTENTION!**

For safety reasons, the requirements in the original instructions must be observed for the iG5A frequency inverter.

## 1. Wiring diagram of connection inverter to electrical network and the fan to inverter

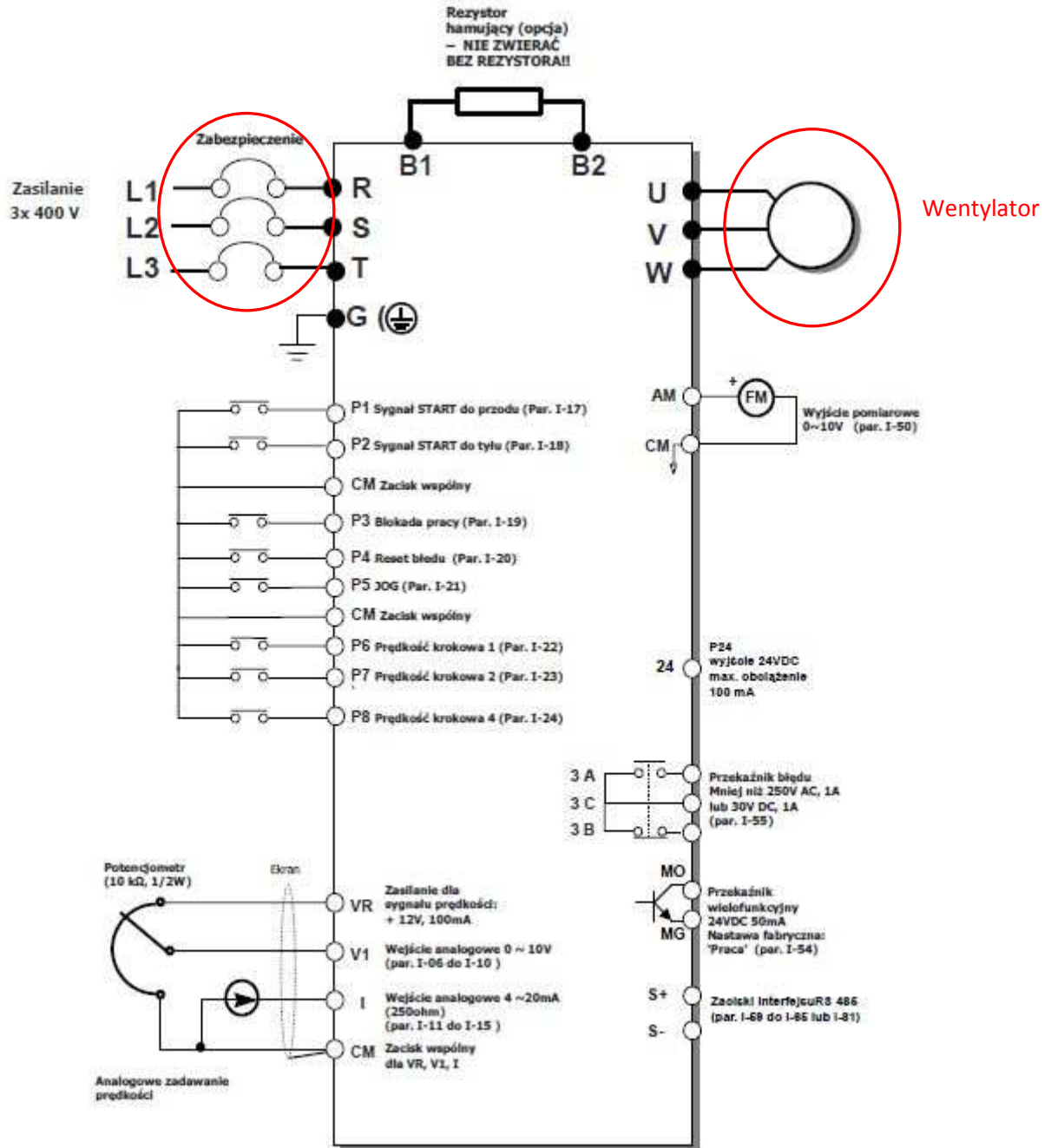

[Rys. 2] Wiring diagram of connection to regulate from inverter panel

## 2. Introduction of inverter parameters

All parameters which we need, we can find in motor rating plate or commute in easy way (if the manufacturer did not supply them).

### a) Rated power

H30	A31E	Rated power of motor	0.2-22	Rated power o motor form rating plate. The power is assigned rated power of inverter.	
				0.2	0.2 kW
				~	~
				18.5	18.5 kW
				22	22 kW



In this case the power of motor is 1.1 kW so the parameter H30 should be set on 1.1.

### b) Number of poles

H31	A31F	Number of poles	2-12	Number of poles written from motor rating plate. This value inverter converts to display rotation speed.
-----	------	-----------------	------	--

If the number of poles is not specified by manufacturer on rating plate it can easily be counted according to the formula:

$$n_1 = \frac{60 \cdot f_1}{p}$$

$p$  — number of poles

$n_1$  - synchronous speed

$f_1$  - current frequency

If we have rotation speed 1425 rpm, we have to take 1500 rpm because this is synchronous speed (without slip) according to the table below:

Number of poles $P$	1	2	3	4	5	6	8	10	12
Rotation speed (rpm)	3000	1500	1000	750	600	500	375	300	250

Transforming the formula to calculate  $p$  you can see that motor has 2 pairs of poles so 4 poles. This is the value of parameter H31 we set on 4.

a) Rated current

H33	A321	Rated current	1.0-150 [A]	Rated current from motor rating plate
-----	------	---------------	-------------	---------------------------------------



For this motor with star connection, the rated current will be 2,5 A, so parameter H33 will be 2.5.

b) Motor current without load

H34	A322	Motor current without load	0.1-50 [A]	Motor current at rated speeds without load. In absence of data you should write 50% of H33 parameter.
-----	------	----------------------------	------------	---

In this case parameter H34 we set on 1,25 (2,5 A / 2).

a) Setting characteristics.

F30	A21E	Characteristic U/f	0:2	0	Liniear
				1	Square
				2	Stworzona przez użytkownika (par. F31-F38)

For fans we use square characteristic.

b) Efficiency

H36	A324	Efficiency	50 – 100[%]	Rated efficiency of motor written from motor rating plate.
-----	------	------------	-------------	--

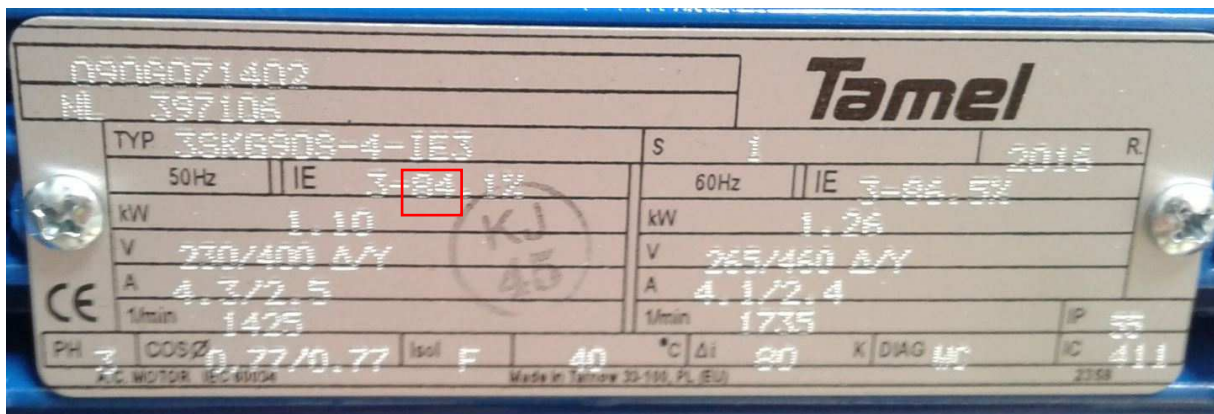

Moto efficiency is 84% so parameter H36 we set on 84.

a) Frequency

F21	A215	Maximum frequency	40-400[Hz]	Maximum frequency which can be obtained at the output of inverter. To this frequency are referred acceleration and braking times. If in paragraph H40 is set to 3 (vector control) – max setting 300Hz.
-----	------	-------------------	------------	--

Maximum frequency of work during engine control is 50Hz.

b) Rated frequency

F22	A216	Base frequency	30-400[Hz]	Rated frequency of motor
-----	------	----------------	------------	--------------------------

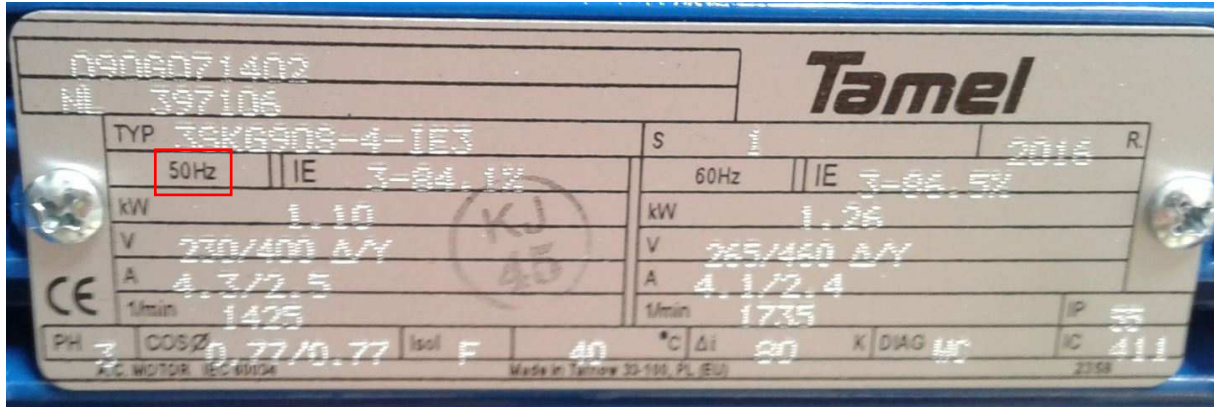

Rated frequency of this motor is 50Hz so parameter F22 we set on 50.

c) Minimum frequency

F23	A217	Initial frequency	0-400[Hz]	Frequency from which inverter starts working.
-----	------	-------------------	-----------	---

Usually it is 25Hz so we should set this value.

d) Motor protection

F50	A232	Choice of electronic thermal protection	0-1	Choice of thermal motor protection.	
				0	No
				1	Yes
F51	A233	The level of electronic thermal protection for 1 minute	50-200[%]	Parameters F51-F53 are displayed when F50=1	
				The setting of maximum current for 1 minute. The value is percent of H33 parameter. It can't be set below F52 parameter.	
F52	A234	The level of electronic thermal protection for continuous work	50-150[%]	The setting of maximum current for continuous work. The value is percent of H33 parameter. It can't be set above F51 parameter.	

You should set F51 parameter on 150% and F52 on 110%.

### 3. Engine control

#### 1) Engine start/stop

Drv	Motor START/STOP Control mode	0-3	0	Start/Stop which i realized through buttons on inverter panel.	
			1	Terminals control mode	FX – Switching forward work RX – Switching backward work
			2		FX – Inverter work RX – Choice of work forw./back.
			3	RS 485 communication	

The value of parameter drv we set on 0 for inverter panel control.

#### 2) Frequency setting method

Frq	Frequency setting method	0-7	0	Digital	Keyboard 1 After pressing the enter button you should set desired frequency and after next pressing the enter button, the inverter will has a new frequency
			1		Keyboard 2 After pressing the enter button you can smoothly adjust the frequency of the inverter with the up/down buttons.
			2	Analog	V1(1) Voltage control of terminal V1 in terms of -10[V]-10[V]
			3		V1(2) Voltage control of terminal V1 in terms of 0-10[V]
			4		I Current control of terminal I in terms of 4-20[mA]
			5		V1(1) + I Simultaneous control of terminal V1 i I
			6		V1(2) + I Simultaneous control of terminal V1 i I
			7		RS 485
			8		Up/down control

The frq parameter we set on 1 for the regulation from inverter panel.



## 4. Conclusions

Correct reading and write the motor parameters to inverter memory will allow the fan of function properly. The above settings will allow for the user start and stop the fan by pressing the button on inverter panel. On the same panel you can set the desired frequency of work. The above settings will also allow to set the inverter parameters so that the speed, start and stop can be remotely.

If there is ambiguity or need for another control of fan, please contact with technical department Venture Industries.

